



MATHEMATICS TEST

60 Minutes—60 Questions

DIRECTIONS: Solve each problem, choose the correct answer, and then fill in the corresponding oval on your answer document.

Do not linger over problems that take too much time. Solve as many as you can; then return to the others in the time you have left for this test.

You are permitted to use a calculator on this test. You may use your calculator for any problems you choose,

but some of the problems may best be done without using a calculator.

Note: Unless otherwise stated, all of the following should be assumed.

1. Illustrative figures are NOT necessarily drawn to scale.
2. Geometric figures lie in a plane.
3. The word *line* indicates a straight line.
4. The word *average* indicates arithmetic mean.

1. Two enterprising college students decide to start a business. They will make up and deliver helium balloon bouquets for special occasions. It will cost them \$39.99 to buy a machine to fill the balloons with helium. They estimate that it will cost them \$2.00 to buy the balloons, helium, and ribbons needed to make each balloon bouquet. Which of the following expressions could be used to model the total cost for producing b balloon bouquets?
 - A. $\$ 2.00b + \39.99
 - B. $\$37.99b$
 - C. $\$39.99b + \$ 2.00$
 - D. $\$41.99b$
 - E. $\$79.98b$
2. What is the value of the expression $(x - y)^2$ when $x = 5$ and $y = -1$?
 - F. 4
 - G. 6
 - H. 16
 - J. 24
 - K. 36
3. On the first day of school, Mr. Vilani gave his third-grade students 5 new words to spell. On each day of school after that, he gave the students 3 new words to spell. In the first 20 days of school, how many new words had he given the students to spell?
 - A. 28
 - B. 62
 - C. 65
 - D. 68
 - E. 152
4. Which of the following is equivalent to $(4x^2)^3$?
 - F. $64x^8$
 - G. $64x^6$
 - H. $12x^6$
 - J. $12x^5$
 - K. $4x^6$
5. Which of the following lists all the positive factors of 8?
 - A. 1, 8
 - B. 2, 4
 - C. 2, 4, 6
 - D. 8, 16, 32
 - E. 1, 2, 4, 8
6. Which of the following is an equivalent simplified expression for $2(4x + 7) - 3(2x - 4)$?
 - F. $x + 2$
 - G. $2x + 2$
 - H. $2x + 26$
 - J. $3x + 10$
 - K. $3x + 11$
7. To determine a student's overall test score for the semester, Ms. Lopez throws out the lowest test score and takes the average of the remaining test scores. Victor earned the following test scores in Ms. Lopez's class this semester: 62, 78, 83, 84, and 93. What overall test score did Victor earn in Ms. Lopez's class this semester?
 - A. 67.6
 - B. 80.0
 - C. 83.0
 - D. 83.5
 - E. 84.5
8. Uptown Cable, a cable TV provider, charges each customer \$120 for installation, plus \$25 per month for cable programming. Uptown's competitor, Downtown Cable, charges each customer \$60 for installation, plus \$35 per month for cable programming. A customer who signs up with Uptown will pay the same total amount for cable TV as a customer who signs up with Downtown if each pays for installation and cable programming for how many months?
 - F. 3
 - G. 6
 - H. 10
 - J. 18
 - K. 30



9. In the 8-sided figure below, adjacent sides meet at right angles and the lengths given are in meters. What is the perimeter of the figure, in meters?

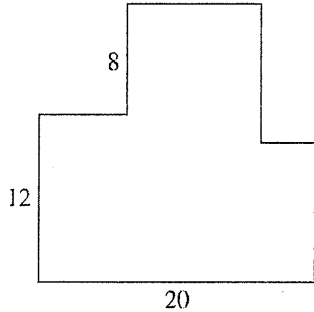

10. The sum of the real numbers x and y is 11. Their difference is 5. What is the value of xy ?

- A. 40
B. 80
C. 120
D. 160
E. 400
11. For all x , $(3x + 7)^2 = ?$
- A. $6x + 14$
B. $6x^2 + 14$
C. $9x^2 + 49$
D. $9x^2 + 21x + 49$
E. $9x^2 + 42x + 49$

12. What is the slope of the line through $(-5, 2)$ and $(6, 7)$ in the standard (x, y) coordinate plane?

- F. 9
G. 5
H. -5
J. $\frac{5}{11}$
K. $-\frac{5}{11}$
13. When $\frac{1}{3}k + \frac{1}{4}k = 1$, what is the value of k ?

- A. $\frac{1}{7}$
B. $\frac{12}{7}$
C. $\frac{7}{2}$
D. 6
E. 12

14. What is the length, in feet, of the hypotenuse of a right triangle with legs that are 6 feet long and 7 feet long, respectively?

- F. $\sqrt{13}$
G. $\sqrt{85}$
H. 13
J. 21
K. 42

15. Hexagon $ABCDEF$ shown below was drawn on a grid with unit squares. Each vertex is at the intersection of 2 grid lines. What is the area of the hexagon, in square units?

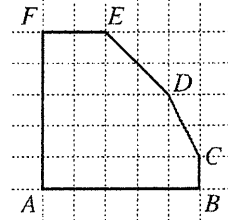

- A. 18
B. 19
C. 20
D. 22
E. 25

16. In the figure below, \overline{AD} is perpendicular to \overline{BD} , \overline{AC} is perpendicular to \overline{BC} , and $\overline{AD} \cong \overline{BC}$. Which of the following congruences is NOT necessarily true?

- F. $\overline{AC} \cong \overline{BD}$
G. $\overline{AD} \cong \overline{AE}$
H. $\overline{AE} \cong \overline{BE}$
J. $\angle DAB \cong \angle CBA$
K. $\angle EAB \cong \angle EBA$

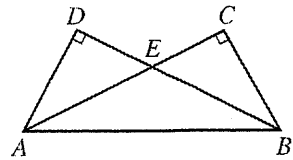

17. Leticia went into Discount Music to price CDs. All CDs were discounted 23% off the marked price. Leticia wanted to program her calculator so she could input the marked price and the discounted price would be the output. Which of the following is an expression for the discounted price on a marked price of p dollars?

- A. $p - 0.23p$
B. $p - 0.23$
C. $p - 23p$
D. $p - 23$
E. $0.23p$

18. In the figure below, A , D , B , and G are collinear. If $\angle CAD$ measures 76° , $\angle BCD$ measures 47° , and $\angle CBG$ measures 140° , what is the degree measure of $\angle ACD$?

- F. 12°
G. 14°
H. 17°
J. 36°
K. 43°

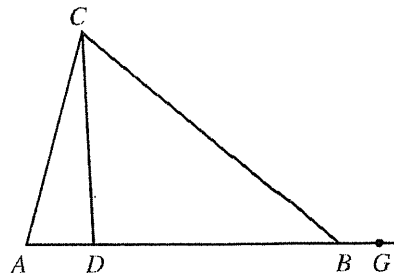



Ms. Lewis plans to drive 900 miles to her vacation destination, driving an average of 50 miles per hour. How many miles per hour faster must she average, while driving, to reduce her total driving time by 3 hours?

- A. 5
- B. 8
- C. 10
- D. 15
- E. 18

20. For all positive integers x , what is the greatest common factor of the 2 numbers $216x$ and $180x$?

- F. 6
- G. 72
- H. x
- J. $12x$
- K. $36x$

21. The table below shows the price of different quantities of standard-sized lemons at Joe's Fruit Stand. What is the least amount of money needed to purchase exactly 20 standard-sized lemons if the bags must be sold intact and there is no tax charged for lemons?

Number of lemons:	1	bag of 6	bag of 12
Total price:	\$0.30	\$1.20	\$2.10

- A. \$3.60
- B. \$3.90
- C. \$4.20
- D. \$4.50
- E. \$6.00

22. The diameter, d centimeters, of the metal poles Goodpole Manufacturing produces must satisfy the inequality $|d - 3| \leq 0.001$. What is the maximum diameter, in centimeters, such a metal pole may have?

- F. 1.4995
- G. 1.5005
- H. 2.999
- J. 3.000
- K. 3.001

23. Which of the following is a factored form of the expression $5x^2 - 13x - 6$?

- A. $(x - 3)(5x + 2)$
- B. $(x - 2)(5x - 3)$
- C. $(x - 2)(5x + 3)$
- D. $(x + 2)(5x - 3)$
- E. $(x + 3)(5x - 2)$

24. A bag contains 6 red marbles, 5 yellow marbles, and 7 green marbles. How many additional red marbles must be added to the 18 marbles already in the bag so that the probability of randomly drawing a red marble is $\frac{3}{5}$?

- F. 12
- G. 16
- H. 18
- J. 24
- K. 36

25. Which of the following trigonometric equations is valid for the side measurement x inches, diagonal measurement y inches, and angle measurement w° in the rectangle shown below?

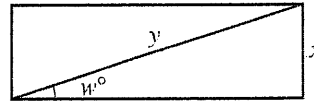

- A. $\cos w^\circ = \frac{x}{y}$
- B. $\cot w^\circ = \frac{x}{y}$
- C. $\sec w^\circ = \frac{x}{y}$
- D. $\sin w^\circ = \frac{x}{y}$
- E. $\tan w^\circ = \frac{x}{y}$

26. The slope of the line with equation $y = ax + b$ is greater than the slope of the line with equation $y = cx + b$. Which of the following statements *must* be true about the relationship between a and c ?

- F. $a \leq c$
- G. $a < c$
- H. $a = c$
- J. $a > c$
- K. $a \geq c + 1$

27. Minh cuts a board in the shape of a regular hexagon and pounds in a nail at an equal distance from each vertex, as shown in the figure below. How many rubber bands will she need in order to stretch a different rubber band across every possible pair of nails?

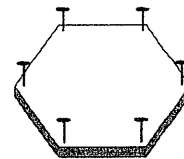

- A. 15
- B. 14
- C. 12
- D. 9
- E. 6

28. There are 280 runners registered for a race, and the runners are divided into 4 age categories, as shown in the table below.

Age category:	under 16	16-25	26-35	over 35
Number of runners:	40	76	112	52

The prize committee has 60 prizes to award and wants the prizes to be awarded in proportion to the number of runners registered in each category. How many prizes should be designated for the 26-35 age category?

- F. 15
- G. 17
- H. 24
- J. 36
- K. 40

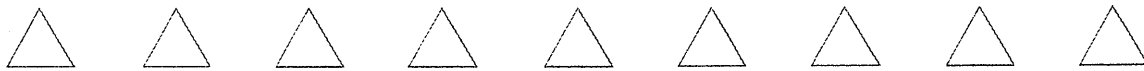

Use the following information to answer questions 29–32.

The youth center has installed a swimming pool on level ground. The pool is a right circular cylinder with a diameter of 24 feet and a height of 6 feet. A diagram of the pool and its entry ladder is shown below.

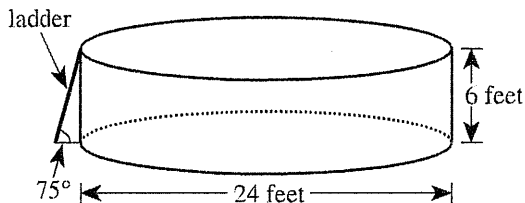

29. To the nearest cubic foot, what is the volume of water that will be in the pool when it is filled with water to a depth of 5 feet?

(Note: The volume of a cylinder is given by $\pi r^2 h$, where r is the radius and h is the height.)

- A. 942
- B. 1,885
- C. 2,262
- D. 9,047
- E. 11,310

30. A plastic cover is made for the pool. The cover will rest on the top of the pool and will include a wedge-shaped flap that forms a 45° angle at the center of the cover, as shown in the figure below. A zipper will go along 1 side of the wedge-shaped flap and around the arc. Which of the following is closest to the length, in feet, of the zipper?

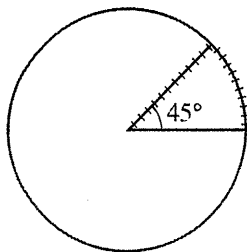

- F. 17
- G. 22
- H. 24
- J. 29
- K. 57

31. Two hoses are used to fill the pool. Twice as many gallons of water per minute flow through one of the hoses as through the other. Both hoses had been on for 12 hours and had filled the pool to the 4-foot mark when the hose with the faster flow stopped working. The hose with the slower flow then finished filling the pool to the 5-foot mark. Which of the following graphs shows the relationship between the time spent filling the pool and the height of the water in the pool?

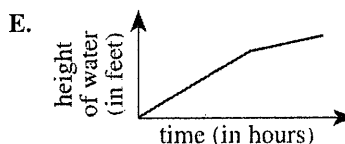
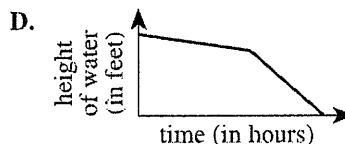
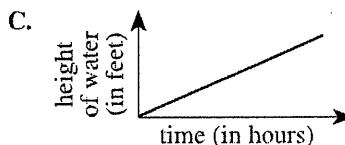
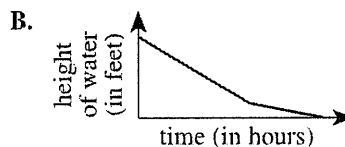
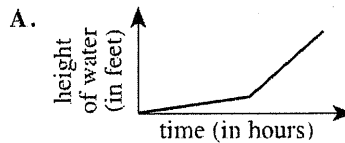

32. The directions for assembling the pool state that the ladder should be placed at an angle of 75° relative to level ground. Which of the following expressions involving tangent gives the distance, in feet, that the bottom of the ladder should be placed away from the bottom edge of the pool in order to comply with the directions?

- F. $\frac{6}{\tan 75^\circ}$
- G. $\frac{\tan 75^\circ}{6}$
- H. $\frac{1}{6 \tan 75^\circ}$
- J. $6 \tan 75^\circ$
- K. $\tan(6 \cdot 75^\circ)$



For a population that grows at a constant rate of $r\%$ per year, the formula $P(t) = p_0\left(1 + \frac{r}{100}\right)^t$ models the population t years after an initial population of p_0 people is counted.

The population of the city of San Jose was 782,000 in 1990. Assume the population grows at a constant rate of 5% per year. According to this formula, which of the following is an expression for the population of San Jose in the year 2000?

- A. $782,000(6)^{10}$
- B. $782,000(1.5)^{10}$
- C. $782,000(1.05)^{10}$
- D. $(782,000 \times 1.5)^{10}$
- E. $(782,000 \times 1.05)^{10}$

36. The inequality $3(x + 2) > 4(x - 3)$ is equivalent to which of the following inequalities?

- F. $x < -6$
- G. $x < 5$
- H. $x < 9$
- J. $x < 14$
- K. $x < 18$

37. In the standard (x,y) coordinate plane, the midpoint of \overline{AB} is $(4,-3)$ and A is located at $(1,-5)$. If (x,y) are the coordinates of B , what is the value of $x + y$?

- A. 19
- B. 8
- C. 6
- D. -1.5
- E. -3

34. Tom's long-distance service charges \$0.10 per minute from 7:00 P.M. to 7:00 A.M. on weekdays, all day on Saturdays, and all day on holidays; \$0.05 per minute all day on Sundays; and \$0.25 per minute at all other times. The table below gives his long-distance calls for 1 week, including the date and day of each call, the time it was placed, and the number of minutes it lasted.

Date and day	Time	Number of minutes
11/22 Tuesday	5:00 P.M.	8
11/23 Wednesday	10:30 A.M.	10
11/24 Thursday Thanksgiving holiday	11:30 A.M.	15
11/26 Saturday	9:30 A.M.	17
11/27 Sunday	12:15 P.M.	22

What did Tom's long-distance service charge him for the calls in the table?

- F. \$7.30
- G. \$7.60
- H. \$7.95
- J. \$8.80
- K. \$9.90

35. The parallel sides of the isosceles trapezoid shown below are 10 feet long and 16 feet long, respectively. What is the distance, in feet, between these 2 sides?

- A. 3
- B. 4
- C. 5
- D. 10
- E. 16

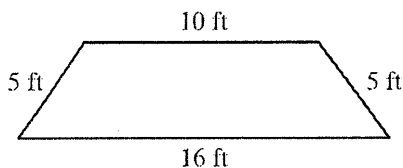

38. For all x in the domain of the function $\frac{x+1}{x^3-x}$, this function is equivalent to:

- F. $\frac{1}{x^2} - \frac{1}{x^3}$
- G. $\frac{1}{x^3} - \frac{1}{x}$
- H. $\frac{1}{x^2 - 1}$
- J. $\frac{1}{x^2 - x}$
- K. $\frac{1}{x^3}$

39. In the figure below, line l is parallel to line m . Transversals t and u intersect at point A on l and intersect m at points C and B , respectively. Point X is on m , the measure of $\angle ACX$ is 130° , and the measure of $\angle BAC$ is 80° . How many of the angles formed by rays of l , m , t , and u have measure 50° ?

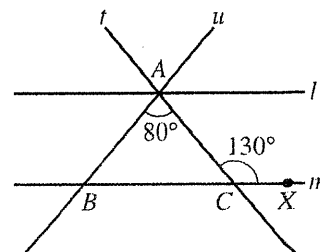

- A. 4
- B. 6
- C. 8
- D. 10
- E. 12



40. Tickets for the Senior Talent Show at George Washington Carver High School are \$3 for adults and \$2 for students. To cover expenses, a total of \$600 must be collected from ticket sales for the show. One of the following graphs in the standard (x,y) coordinate plane, where x is the number of adult tickets sold and y is the number of student tickets sold, represents all the possible combinations of ticket sales that cover at least \$600 in expenses. Which graph is it?

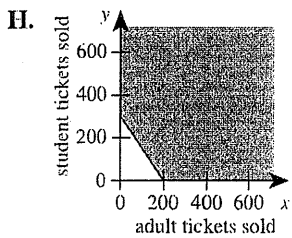
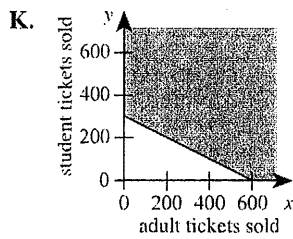
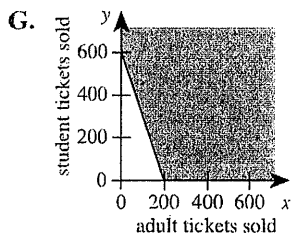
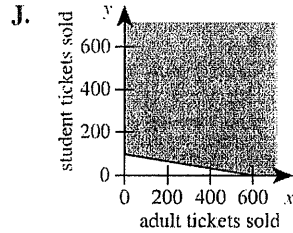
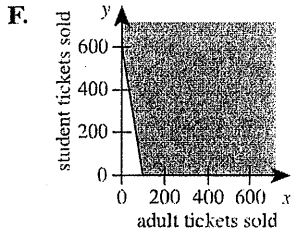

41. What is the median of the following 7 scores?

42, 67, 33, 79, 33, 89, 21

- A. 42
- B. 52
- C. 54.5
- D. 56
- E. 79

42. What are the real solutions to the equation

$$|x|^2 + 2|x| - 3 = 0?$$

- F. ± 1
- G. ± 3
- H. 1 and 3
- J. -1 and -3
- K. ± 1 and ± 3

43. The point $(2,5)$ is shown in the standard (x,y) coordinate plane below. Which of the following is another point on the line through the point $(2,5)$ with a slope of $-\frac{2}{3}$?

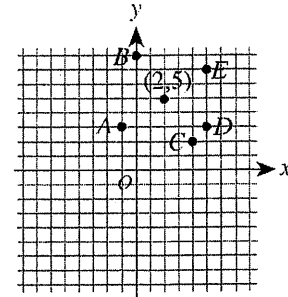

- A. $A(-1,3)$
- B. $B(0,8)$
- C. $C(4,2)$
- D. $D(5,3)$
- E. $E(5,7)$

44. For the triangles in the figure below, which of the following ratios of side lengths is equivalent to the ratio of the perimeter of $\triangle ABC$ to the perimeter of $\triangle DAB$?

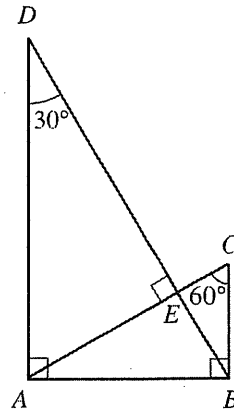

- F. $AB:AD$
- G. $AB:BD$
- H. $AD:BD$
- J. $BC:AD$
- K. $BC:BD$

45. In the figure below, 2 nonadjacent sides of a regular pentagon (5 congruent sides and 5 congruent interior angles) are extended until they meet at point X . What is the measure of $\angle X$?

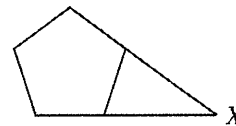

- A. 18°
- B. 30°
- C. 36°
- D. 45°
- E. 72°

46. The edges of a cube are each 3 inches long. What is the surface area, in square inches, of this cube?

- F. 9
- G. 18
- H. 27
- J. 36
- K. 54



47. A number is increased by 25% and the resulting number is then decreased by 20%. The final number is what percent of the original number?

- A. 90%
- B. 95%
- C. 100%
- D. 105%
- E. 120%

48. Two numbers are *reciprocals* if their product is equal to 1. If x and y are reciprocals and $x > 1$, then y must be:

- F. less than -1 .
- G. between 0 and -1 .
- H. equal to 0.
- J. between 0 and 1.
- K. greater than 1.

49. The number line graph below is the graph of which of the following inequalities?

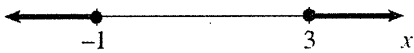

- A. $-1 \leq x$ and $3 \leq x$
- B. $-1 \leq x$ and $3 \geq x$
- C. $-1 \leq x$ or $3 \leq x$
- D. $-1 \geq x$ or $3 \leq x$
- E. $-1 \geq x$ or $3 \geq x$

50. All of the following graphs have equal scales on the axes. One of the graphs shows only points for which the y -coordinate is 1 less than the square of the x -coordinate. Which one?

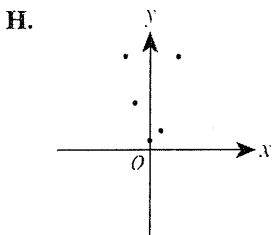
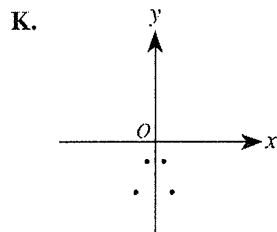
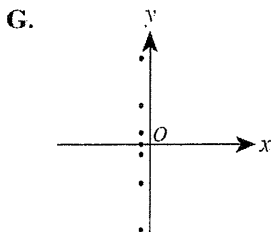
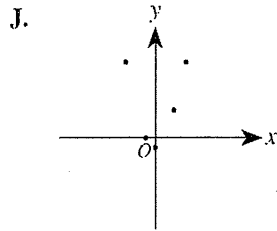
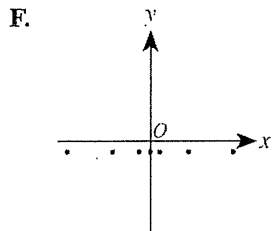

51. In teaching a lesson on the concept of thirds, Ms. Chu uses a divide-and-set-aside procedure. She starts with a certain number of colored disks, divides them into 3 equal groups, and sets 1 group aside to illustrate $\frac{1}{3}$. She repeats the procedure by taking the disks she had NOT set aside, dividing them into 3 equal groups, and setting 1 of these groups aside. If Ms. Chu wants to be able to complete the divide-and-set-aside procedure at least 4 times (without breaking any of the disks into pieces), which of the following is the minimum number of colored disks she can start with?

- A. 12
- B. 15
- C. 27
- D. 54
- E. 81

52. Which of the following is true for all consecutive integers m and n such that $m < n$?

- F. m is odd
- G. n is odd
- H. $n - m$ is even
- J. $n^2 - m^2$ is odd
- K. $m^2 + n^2$ is even

53. A function P is defined as follows:

$$\begin{aligned} \text{for } x > 0, P(x) &= x^5 + x^4 - 36x - 36 \\ \text{for } x < 0, P(x) &= -x^5 + x^4 + 36x - 36 \end{aligned}$$

What is the value of $P(-1)$?

- A. -70
- B. -36
- C. 0
- D. 36
- E. 70

54. For a project in Home Economics class, Kirk is making a tablecloth for a circular table 3 feet in diameter. The finished tablecloth needs to hang down 5 inches over the edge of the table all the way around. To finish the edge of the tablecloth, Kirk will fold under and sew down 1 inch of the material all around the edge. Kirk is going to use a single piece of rectangular fabric that is 60 inches wide. What is the shortest length of fabric, in inches, Kirk could use to make the tablecloth without putting any separate pieces of fabric together?

- F. 15
- G. 24
- H. 30
- J. 42
- K. 48



55. The equations of the 2 graphs shown below are $y_1(t) = a_1 \sin(b_1 t)$ and $y_2(t) = a_2 \cos(b_2 t)$, where the constants b_1 and b_2 are both positive real numbers.

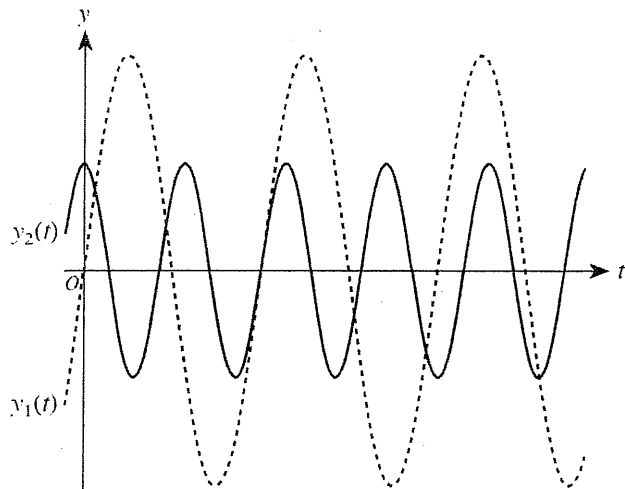

Which of the following statements is true of the constants a_1 and a_2 ?

- A. $0 < a_1 < a_2$
 B. $0 < a_2 < a_1$
 C. $a_1 < 0 < a_2$
 D. $a_1 < a_2 < 0$
 E. $a_2 < a_1 < 0$
56. For x such that $0 < x < \frac{\pi}{2}$, the expression $\frac{\sqrt{1 - \cos^2 x}}{\sin x} + \frac{\sqrt{1 - \sin^2 x}}{\cos x}$ is equivalent to:
- F. 0
 G. 1
 H. 2
 J. $-\tan x$
 K. $\sin 2x$
57. Consider the functions $f(x) = \sqrt{x}$ and $g(x) = 7x + b$. In the standard (x, y) coordinate plane, $y = f(g(x))$ passes through $(4, 6)$. What is the value of b ?
- A. 8
 B. -8
 C. -25
 D. -26
 E. $4 - 7\sqrt{6}$

58. The triangle, $\triangle XYZ$, that is shown below has side lengths of x , y , and z inches and is not a right triangle. Let X' be the image of X when the triangle is reflected across \overline{YZ} . Which of the following is an expression for the perimeter, in inches, of quadrilateral $X'YXZ$?

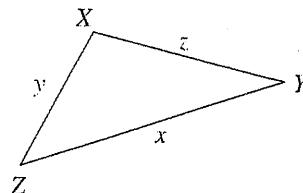

- F. $2(y + z) + x$
 G. $2(x + y + z)$
 H. $2(x + y)$
 J. $2(x + z)$
 K. $2(y + z)$
59. A function f is an *odd* function if and only if $f(-x) = -f(x)$ for every value of x in the domain of f . One of the functions graphed in the standard (x, y) coordinate plane below is an odd function. Which one?

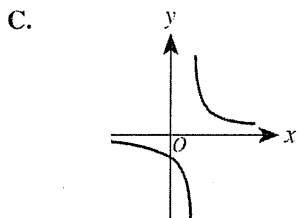
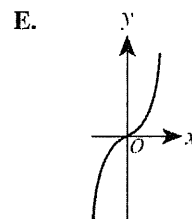
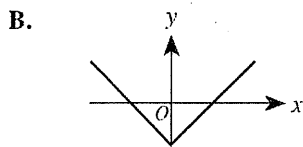
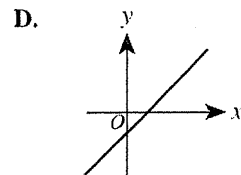
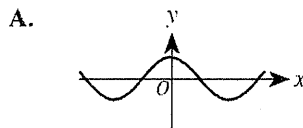

60. What is the real value of x in the equation $\log_2 24 - \log_2 3 = \log_5 x$?
- F. 3
 G. 21
 H. 72
 J. 125
 K. 243

END OF TEST 2

STOP! DO NOT TURN THE PAGE UNTIL TOLD TO DO SO.

DO NOT RETURN TO THE PREVIOUS TEST.

Test 2: Mathematics—Scoring Key

	Key	Subscore Area*				Key	Subscore Area*		
		EA	AG	GT			EA	AG	GT
1.	A	_____			31.	E	_____		
2.	K	_____			32.	F			_____
3.	B	_____			33.	C	_____		
4.	G		_____		34.	J	_____		
5.	E	_____			35.	B			_____
6.	H	_____			36.	K		_____	
7.	E	_____			37.	C	_____		
8.	G	_____			38.	J	_____		
9.	B			_____	39.	C			_____
10.	J		_____		40.	H	_____		
11.	E	_____			41.	A	_____		
12.	J		_____		42.	F		_____	
13.	B	_____			43.	D		_____	
14.	G			_____	44.	F		_____	
15.	C			_____	45.	C		_____	
16.	G			_____	46.	K		_____	
17.	A	_____			47.	C	_____		
18.	H			_____	48.	J	_____		
19.	C	_____			49.	D		_____	
20.	K	_____			50.	J		_____	
21.	B	_____			51.	E	_____		
22.	K		_____		52.	J	_____		
23.	A	_____			53.	A		_____	
24.	F	_____			54.	K		_____	
25.	D			_____	55.	B		_____	
26.	J		_____		56.	H		_____	
27.	A	_____			57.	A	_____		
28.	H	_____			58.	K		_____	
29.	C			_____	59.	E	_____		
30.	G			_____	60.	J	_____		

Number Correct (Raw Score) for:	
Pre-Alg./Elem. Alg. (EA) Subscore Area	_____ (24)
Inter. Alg./Coord. Geo. (AG) Subscore Area	_____ (18)
Plane Geo./Trig. (GT) Subscore Area	_____ (18)
Total Number Correct for Math Test (EA + AG + GT)	_____ (60)

* EA = Pre-Algebra/Elementary Algebra
 AG = Intermediate Algebra/Coordinate Geometry
 GT = Plane Geometry/Trigonometry

0661C

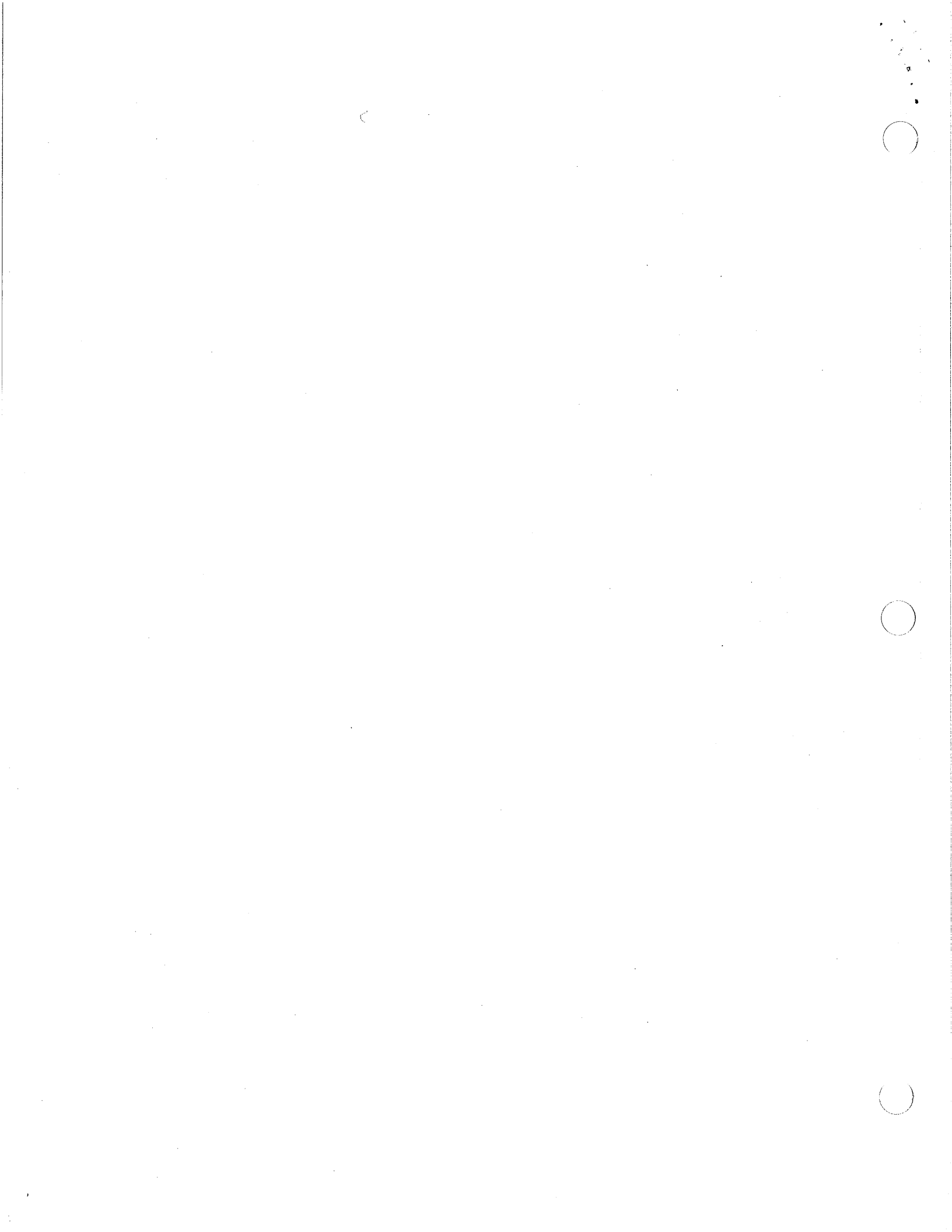



Key

Test #2
(2019)

MATHEMATICS TEST

60 Minutes—60 Questions

DIRECTIONS: Solve each problem, choose the correct answer, and then fill in the corresponding oval on your answer document.

Do not linger over problems that take too much time. Solve as many as you can; then return to the others in the time you have left for this test.

You are permitted to use a calculator on this test. You may use your calculator for any problems you choose,

but some of the problems may best be done without using a calculator.

Note: Unless otherwise stated, all of the following should be assumed.

1. Illustrative figures are NOT necessarily drawn to scale.
2. Geometric figures lie in a plane.
3. The word *line* indicates a straight line.
4. The word *average* indicates arithmetic mean.

1. Two enterprising college students decide to start a business. They will make up and deliver helium balloon bouquets for special occasions. It will cost them \$39.99 to buy a machine to fill the balloons with helium. They estimate that it will cost them \$2.00 to buy the balloons, helium, and ribbons needed to make each balloon bouquet. Which of the following expressions could be used to model the total cost for producing b balloon bouquets?
 - A. $\$ 2.00b + \39.99
 - B. $\$37.99b$
 - C. $\$39.99b + \$ 2.00$
 - D. $\$41.99b$
 - E. $\$79.98b$
2. What is the value of the expression $(x - y)^2$ when $x = 5$ and $y = -1$?
 - F. 4
 - G. 6
 - H. 16
 - J. 24
 - K. 36
3. On the first day of school, Mr. Vilani gave his third-grade students 5 new words to spell. On each day of school after that, he gave the students 3 new words to spell. In the first 20 days of school, how many new words had he given the students to spell?
 - A. 28
 - B. 62
 - C. 65
 - D. 68
 - E. 152
4. Which of the following is equivalent to $(4x^2)^3$?
 - F. $64x^8$
 - G. $64x^6$
 - H. $12x^6$
 - J. $12x^5$
 - K. $4x^6$
5. Which of the following lists all the positive factors of 8?
 - A. 1, 8
 - B. 2, 4
 - C. 2, 4, 6
 - D. 8, 16, 32
 - E. 1, 2, 4, 8
6. Which of the following is an equivalent simplified expression for $2(4x + 7) - 3(2x - 4)$?
 - F. $x + 2$
 - G. $2x + 2$
 - H. $2x + 26$
 - J. $3x + 10$
 - K. $3x + 11$
7. To determine a student's overall test score for the semester, Ms. Lopez throws out the lowest test score and takes the average of the remaining test scores. Victor earned the following test scores in Ms. Lopez's class this semester: 62, 78, 83, 84, and 93. What overall test score did Victor earn in Ms. Lopez's class this semester?
 - A. 67.6
 - B. 80.0
 - C. 83.0
 - D. 83.5
 - E. 84.5
8. Uptown Cable, a cable TV provider, charges each customer \$120 for installation, plus \$25 per month for cable programming. Uptown's competitor, Downtown Cable, charges each customer \$60 for installation, plus \$35 per month for cable programming. A customer who signs up with Uptown will pay the same total amount for cable TV as a customer who signs up with Downtown if each pays for installation and cable programming for how many months?
 - F. 3
 - G. 6
 - H. 10
 - J. 18
 - K. 30



9. In the 8-sided figure below, adjacent sides meet at right angles and the lengths given are in meters. What is the perimeter of the figure, in meters?

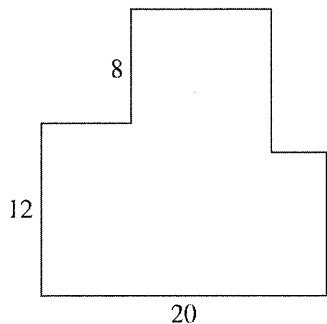

- A. 40
 B. 80
 C. 120
 D. 160
 E. 400

10. The sum of the real numbers x and y is 11. Their difference is 5. What is the value of xy ?

- F. 3
 G. 5
 H. 8
 J. 24
 K. 55

11. For all x , $(3x + 7)^2 = ?$

- A. $6x + 14$
 B. $6x^2 + 14$
 C. $9x^2 + 49$
 D. $9x^2 + 21x + 49$
 E. $9x^2 + 42x + 49$

12. What is the slope of the line through $(-5, 2)$ and $(6, 7)$ in the standard (x, y) coordinate plane?

- F. 9
 G. 5
 H. -5
 J. $\frac{5}{11}$
 K. $-\frac{5}{11}$

13. When $\frac{1}{3}k + \frac{1}{4}k = 1$, what is the value of k ?

- A. $\frac{1}{7}$
 B. $\frac{12}{7}$
 C. $\frac{7}{2}$
 D. 6
 E. 12

14. What is the length, in feet, of the hypotenuse of a right triangle with legs that are 6 feet long and 7 feet long, respectively?

$36 + 49 = \sqrt{85}$

- F. $\sqrt{13}$
 G. $\sqrt{85}$
 H. 13
 J. 21
 K. 42

15. Hexagon $ABCDEF$ shown below was drawn on a grid with unit squares. Each vertex is at the intersection of 2 grid lines. What is the area of the hexagon, in square units?

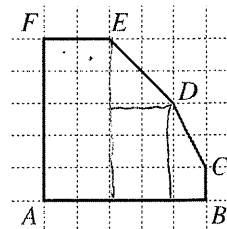

- A. 18
 B. 19
 C. 20
 D. 22
 E. 25

16. In the figure below, \overline{AD} is perpendicular to \overline{BD} , \overline{AC} is perpendicular to \overline{BC} , and $\overline{AD} \cong \overline{BC}$. Which of the following congruences is NOT necessarily true?

- F. $\overline{AC} \cong \overline{BD}$
 G. $\overline{AD} \cong \overline{AE}$
 H. $\overline{AE} \cong \overline{BE}$
 J. $\angle DAB \cong \angle CBA$
 K. $\angle EAB \cong \angle EBA$

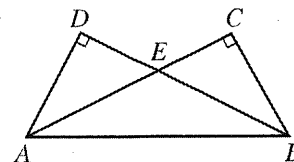

17. Leticia went into Discount Music to price CDs. All CDs were discounted 23% off the marked price. Leticia wanted to program her calculator so she could input the marked price and the discounted price would be the output. Which of the following is an expression for the discounted price on a marked price of p dollars?

- A. $p - 0.23p$
 B. $p - 0.23$
 C. $p - 23p$
 D. $p - 23$
 E. $0.23p$

18. In the figure below, $A, D, B,$ and G are collinear. If $\angle CAD$ measures 76° , $\angle BCD$ measures 47° , and $\angle CBG$ measures 140° , what is the degree measure of $\angle ACD$?

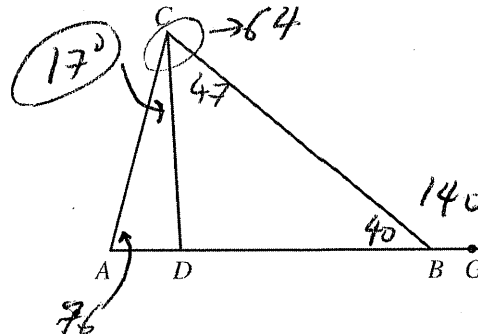

- F. 12°
 G. 14°
 H. 17°
 J. 36°
 K. 43°



$\frac{900}{50} = 18 \text{ hrs.}$

19. Ms. Lewis plans to drive 900 miles to her vacation destination, driving an average of 50 miles per hour. How many miles per hour faster must she average, while driving, to reduce her total driving time by 3 hours?

- A. 5
- B. 8
- C. 10
- D. 15
- E. 18

$\frac{900}{50+x} = 15$

$15(50+x) = 900$

$750 + 15x = 900$

$15x = 150$

$x = 10$

20. For all positive integers x , what is the greatest common factor of the 2 numbers $216x$ and $180x$?

- F. 6
- G. 72
- H. x
- J. $12x$
- K. $36x$

21. The table below shows the price of different quantities of standard-sized lemons at Joe's Fruit Stand. What is the least amount of money needed to purchase exactly 20 standard-sized lemons if the bags must be sold intact and there is no tax charged for lemons?

Number of lemons:	1	bag of 6	bag of 12
Total price:	\$0.30	\$1.20	\$2.10

- A. \$3.60
- B. \$3.90
- C. \$4.20
- D. \$4.50
- E. \$6.00

$3(1.20) + 0.3 = 3.90$

22. The diameter, d centimeters, of the metal poles Goodpole Manufacturing produces must satisfy the inequality $|d - 3| \leq 0.001$. What is the maximum diameter, in centimeters, such a metal pole may have?

- F. 1.4995
- G. 1.5005
- H. 2.999
- J. 3.000
- K. 3.001

$-0.001 \leq d - 3 \leq 0.001$

$2.999 \leq d \leq 3.001$

23. Which of the following is a factored form of the expression $5x^2 - 13x - 6$?

- A. $(x - 3)(5x + 2)$
- B. $(x - 2)(5x - 3)$
- C. $(x - 2)(5x + 3)$
- D. $(x + 2)(5x - 3)$
- E. $(x + 3)(5x - 2)$

24. A bag contains 6 red marbles, 5 yellow marbles, and 7 green marbles. How many additional red marbles must be added to the 18 marbles already in the bag so that the probability of randomly drawing a red marble is $\frac{3}{5}$?

- F. 12
- G. 16
- H. 18
- J. 24
- K. 36

$\frac{6+x}{18+x} = \frac{3}{5}$

$30 + 5x = 54 + 3x$

$24 = 2x$

$x = 12$

25. Which of the following trigonometric equations is valid for the side measurement x inches, diagonal measurement y inches, and angle measurement w° in the rectangle shown below?

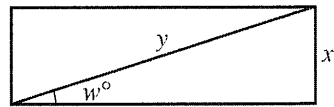

- A. $\cos w^\circ = \frac{x}{y}$
- B. $\cot w^\circ = \frac{x}{y}$
- C. $\sec w^\circ = \frac{x}{y}$
- D. $\sin w^\circ = \frac{x}{y}$
- E. $\tan w^\circ = \frac{x}{y}$

26. The slope of the line with equation $y = ax + b$ is greater than the slope of the line with equation $y = cx + b$. Which of the following statements *must* be true about the relationship between a and c ?

- F. $a \leq c$
- G. $a < c$
- H. $a = c$
- J. $a > c$
- K. $a \geq c + 1$

$a > c$

27. Minh cuts a board in the shape of a regular hexagon and pounds in a nail at an equal distance from each vertex, as shown in the figure below. How many rubber bands will she need in order to stretch a different rubber band across every possible pair of nails?

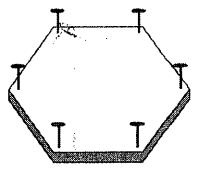

- A. 15
- B. 14
- C. 12
- D. 9
- E. 6

28. There are 280 runners registered for a race, and the runners are divided into 4 age categories, as shown in the table below.

Age category:	under 16	16-25	26-35	over 35
Number of runners:	40	76	112	52

The prize committee has 60 prizes to award and wants the prizes to be awarded in proportion to the number of runners registered in each category. How many prizes should be designated for the 26-35 age category?

- F. 15
- G. 17
- H. 24
- J. 36
- K. 40

$\frac{112}{280} = 0.4(60) = 24$

GO ON TO THE NEXT PAGE.



Use the following information to answer questions 29–32.

The youth center has installed a swimming pool on level ground. The pool is a right circular cylinder with a diameter of 24 feet and a height of 6 feet. A diagram of the pool and its entry ladder is shown below.

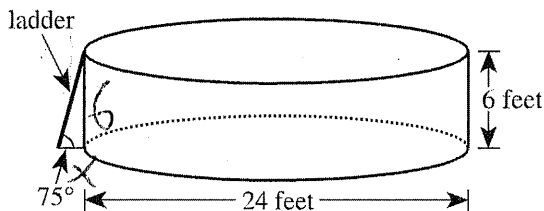

29. To the nearest cubic foot, what is the volume of water that will be in the pool when it is filled with water to a depth of 5 feet?

(Note: The volume of a cylinder is given by $\pi r^2 h$, where r is the radius and h is the height.)

- A. 942
- B. 1,885
- C. 2,262
- D. 9,047
- E. 11,310

$\pi(5)$

$\pi(12)^2(5)$

30. A plastic cover is made for the pool. The cover will rest on the top of the pool and will include a wedge-shaped flap that forms a 45° angle at the center of the cover, as shown in the figure below. A zipper will go along 1 side of the wedge-shaped flap and around the arc. Which of the following is closest to the length, in feet, of the zipper?

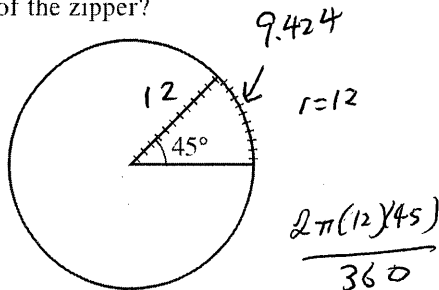

- F. 17
- G. 22
- H. 24
- J. 29
- K. 57

9.424

$r = 12$

$\frac{2\pi(12)(45)}{360}$

Arc Length = $\frac{2\pi\theta}{360}$ =

$9.424 + 12 = 21.42$

31. Two hoses are used to fill the pool. Twice as many gallons of water per minute flow through one of the hoses as through the other. Both hoses had been on for 12 hours and had filled the pool to the 4-foot mark when the hose with the faster flow stopped working. The hose with the slower flow then finished filling the pool to the 5-foot mark. Which of the following graphs shows the relationship between the time spent filling the pool and the height of the water in the pool?

- A.
- B.
- C.
- D.
- E.

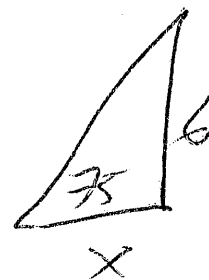

32. The directions for assembling the pool state that the ladder should be placed at an angle of 75° relative to level ground. Which of the following expressions involving tangent gives the distance, in feet, that the bottom of the ladder should be placed away from the bottom edge of the pool in order to comply with the directions?

- F. $\frac{6}{\tan 75^\circ}$
- G. $\frac{\tan 75^\circ}{6}$
- H. $\frac{1}{6 \tan 75^\circ}$
- J. $6 \tan 75^\circ$
- K. $\tan(6 \cdot 75^\circ)$

$\tan \theta = \frac{6}{x}$

$\tan 75^\circ = \frac{6}{x}$

$x = \frac{6}{\tan 75^\circ}$



33. For a population that grows at a constant rate of $r\%$ per year, the formula $P(t) = p_0\left(1 + \frac{r}{100}\right)^t$ models the population t years after an initial population of p_0 people is counted.

The population of the city of San Jose was 782,000 in 1990. Assume the population grows at a constant rate of 5% per year. According to this formula, which of the following is an expression for the population of San Jose in the year 2000?

- A. $782,000(6)^{10}$
- B. $782,000(1.5)^{10}$
- C. $782,000(1.05)^{10}$
- D. $(782,000 \times 1.5)^{10}$
- E. $(782,000 \times 1.05)^{10}$

34. Tom's long-distance service charges \$0.10 per minute from 7:00 P.M. to 7:00 A.M. on weekdays, all day on Saturdays, and all day on holidays; \$0.05 per minute all day on Sundays; and \$0.25 per minute at all other times. The table below gives his long-distance calls for 1 week, including the date and day of each call, the time it was placed, and the number of minutes it lasted.

Date and day	Time	Number of minutes
11/22 Tuesday	5:00 P.M.	8
11/23 Wednesday	10:30 A.M.	10
11/24 Thursday Thanksgiving holiday	11:30 A.M.	15
11/26 Saturday	9:30 A.M.	17
11/27 Sunday	12:15 P.M.	22

What did Tom's long-distance service charge him for the calls in the table?

- F. \$7.30
- G. \$7.60
- H. \$7.95
- J. \$8.80
- K. \$9.90

35. The parallel sides of the isosceles trapezoid shown below are 10 feet long and 16 feet long, respectively. What is the distance, in feet, between these 2 sides?

- A. 3
- B. 4
- C. 5
- D. 10
- E. 16

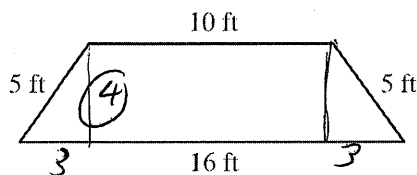

36. The inequality $3(x + 2) > 4(x - 3)$ is equivalent to which of the following inequalities?

- F. $x < -6$
- G. $x < 5$
- H. $x < 9$
- J. $x < 14$
- K. $x < 18$

37. In the standard (x,y) coordinate plane, the midpoint of \overline{AB} is $(4,-3)$ and A is located at $(1,-5)$. If (x,y) are the coordinates of B , what is the value of $x + y$?

- A. 19
- B. 8
- C. 6
- D. -1.5
- E. -3

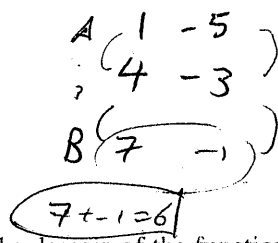

38. For all x in the domain of the function $\frac{x+1}{x^3-x}$, this function is equivalent to:

- F. $\frac{1}{x^2} - \frac{1}{x^3}$
- G. $\frac{1}{x^3} - \frac{1}{x}$
- H. $\frac{1}{x^2-1}$
- J. $\frac{1}{x^2-x}$
- K. $\frac{1}{x^3}$

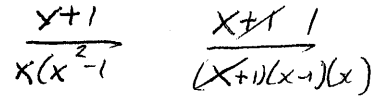

39. In the figure below, line l is parallel to line m . Transversals t and u intersect at point A on l and intersect m at points C and B , respectively. Point X is on m , the measure of $\angle ACX$ is 130° , and the measure of $\angle BAC$ is 80° . How many of the angles formed by rays of l , m , t , and u have measure 50° ?

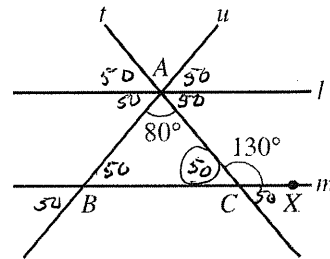

- A. 4
- B. 6
- C. 8
- D. 10
- E. 12



40. Tickets for the Senior Talent Show at George Washington Carver High School are \$3 for adults and \$2 for students. To cover expenses, a total of \$600 must be collected from ticket sales for the show. One of the following graphs in the standard (x,y) coordinate plane, where x is the number of adult tickets sold and y is the number of student tickets sold, represents all the possible combinations of ticket sales that cover at least \$600 in expenses. Which graph is it?

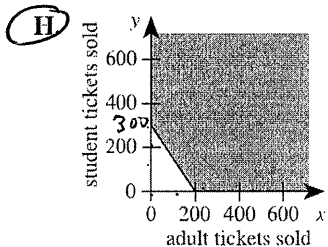
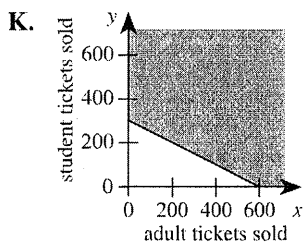
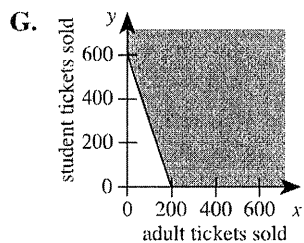
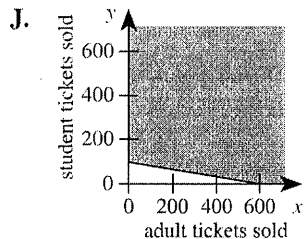
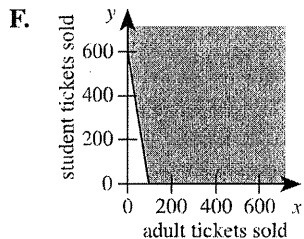

$3a + 2s = 600$
 $2s > 600 - 3a$
 $s > 300 - \frac{3}{2}a$

41. What is the median of the following 7 scores?
 42, 67, 33, 79, 33, 89, 21

- A. 42
 B. 52
 C. 54.5
 D. 56
 E. 79
- Handwritten: 21, 33, 33, 42, 67, 79, 89

42. What are the real solutions to the equation $|x|^2 + 2|x| - 3 = 0$?

- F. ± 1
 G. ± 3
 H. 1 and 3
 J. -1 and -3
 K. ± 1 and ± 3

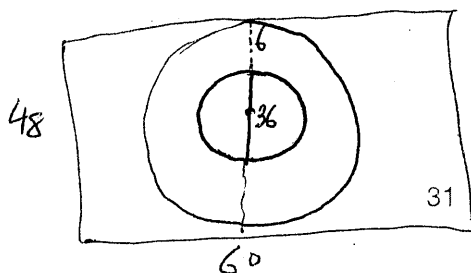

43. The point (2,5) is shown in the standard (x,y) coordinate plane below. Which of the following is another point on the line through the point (2,5) with a slope of $-\frac{2}{3}$?

- A. A(-1,3)
 B. B(0,8)
 C. C(4,2)
 D. D(5,3)
 E. E(5,7)

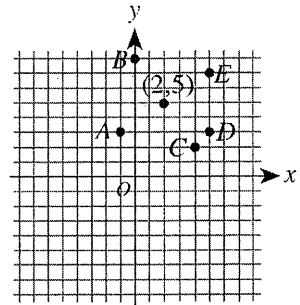

44. For the triangles in the figure below, which of the following ratios of side lengths is equivalent to the ratio of the perimeter of $\triangle ABC$ to the perimeter of $\triangle DAB$?

$\frac{ABC}{DAB} \rightarrow \frac{x + \frac{x}{\sqrt{3}} + x\sqrt{3}}{x + x\sqrt{3} + 2x}$
 $\frac{\sqrt{3}x + x + 3x}{x + x\sqrt{3} + 2x}$

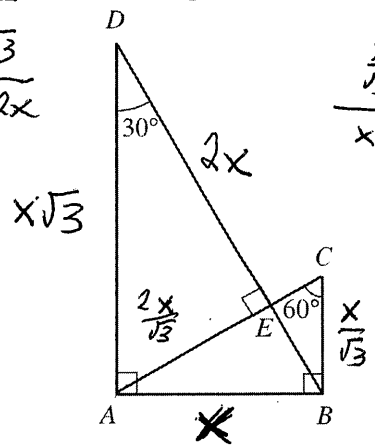

- E. AB:AD
 G. AB:BD
 H. AD:BD
 J. BC:AD
 K. BC:BD

45. In the figure below, 2 nonadjacent sides of a regular pentagon (5 congruent sides and 5 congruent interior angles) are extended until they meet at point X. What is the measure of $\angle X$?

$180 \times 5 = 540$
 $\frac{540}{5} = 108$

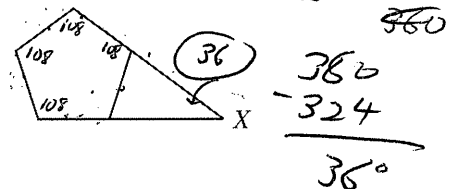

- A. 18°
 B. 30°
 C. 36°
 D. 45°
 E. 72°

46. The edges of a cube are each 3 inches long. What is the surface area, in square inches, of this cube?

- F. 9
 G. 18
 H. 27
 I. 36
 K. 54

SA: $6x^2$
 $6(3)^2 = 54$

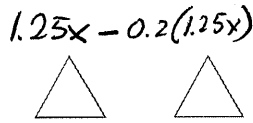
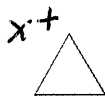

47. A number is increased by 25% and the resulting number is then decreased by 20%. The final number is what percent of the original number?

- A. 90%
- B. 95%
- C. 100%**
- D. 105%
- E. 120%

$1.25x - 0.25 = 100\%$

48. Two numbers are *reciprocals* if their product is equal to 1. If x and y are reciprocals and $x > 1$, then y must be:

- F. less than -1 .
- G. between 0 and -1 .
- H. equal to 0.
- I. between 0 and 1.**
- K. greater than 1.

$x = \frac{2}{1.5} = \frac{4}{3}$
 $y = \frac{1}{x} = \frac{3}{4}$

49. The number line graph below is the graph of which of the following inequalities?

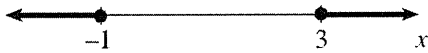

- A. $-1 \leq x$ and $3 \leq x$
- B. $-1 \leq x$ and $3 \geq x$
- C. $-1 \leq x$ or $3 \leq x$
- D. $-1 \geq x$ or $3 \leq x$**
- E. $-1 \geq x$ or $3 \geq x$

50. All of the following graphs have equal scales on the axes. One of the graphs shows only points for which the y -coordinate is 1 less than the square of the x -coordinate. Which one?

F.

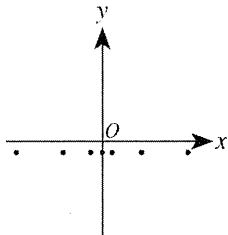

J.

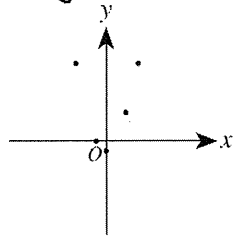

G.

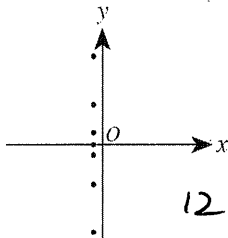

K.

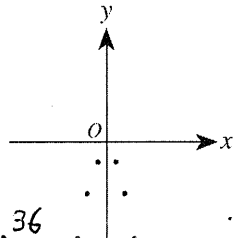

H.

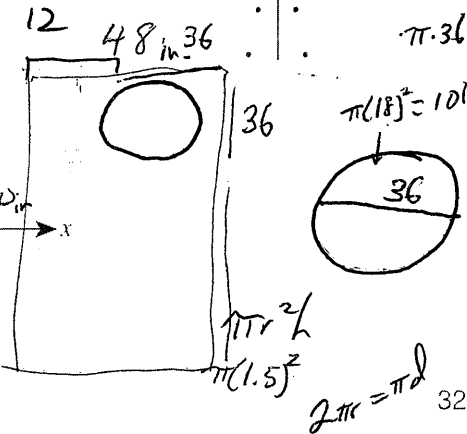
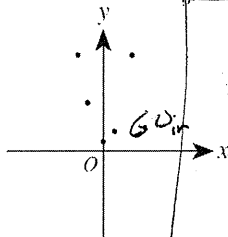

51. In teaching a lesson on the concept of thirds, Ms. Chu uses a divide-and-set-aside procedure. She starts with a certain number of colored disks, divides them into 3 equal groups, and sets 1 group aside to illustrate $\frac{1}{3}$. She repeats the procedure by taking the disks she had NOT set aside, dividing them into 3 equal groups, and setting 1 of these groups aside. If Ms. Chu wants to be able to complete the divide-and-set-aside procedure at least 4 times (without breaking any of the disks into pieces), which of the following is the minimum number of colored disks she can start with?

- A. 12
- B. 15
- C. 27
- D. 54
- E. 81**

$\frac{81}{3} = 27$
 $\frac{27}{3} = 9$
 $\frac{9}{3} = 3$
 $\frac{3}{3} = 1$

52. Which of the following is true for all consecutive integers m and n such that $m < n$?

- F. m is odd
- G. n is odd
- H. $n - m$ is even
- J. $n^2 - m^2$ is odd**
- K. $m^2 + n^2$ is even

- 1, 2
- 3, 2
- 4, 3
- 5, 4

53. A function P is defined as follows:

for $x > 0$, $P(x) = x^5 + x^4 - 36x - 36$
 for $x < 0$, $P(x) = -x^5 + x^4 + 36x - 36$

What is the value of $P(-1)$?

- A. -70**
- B. -36
- C. 0
- D. 36
- E. 70

$-(-1) + 1 - 36 - 36 = -70$

54. For a project in Home Economics class, Kirk is making a tablecloth for a circular table 3 feet in diameter. The finished tablecloth needs to hang down 5 inches over the edge of the table all the way around. To finish the edge of the tablecloth, Kirk will fold under and sew down 1 inch of the material all around the edge. Kirk is going to use a single piece of rectangular fabric that is 60 inches wide. What is the shortest length of fabric, in inches, Kirk could use to make the tablecloth without putting any separate pieces of fabric together?

- F. 15
- G. 24
- H. 30
- I. 42
- K. 48**

$\frac{1696.46}{60} = 28.27$

$3\pi(6) = 18\pi + \pi(1.5)^2 = 63.617$

GO ON TO THE NEXT PAGE.

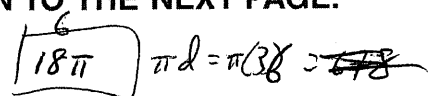
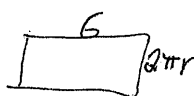



55. The equations of the 2 graphs shown below are $y_1(t) = a_1 \sin(b_1 t)$ and $y_2(t) = a_2 \cos(b_2 t)$, where the constants b_1 and b_2 are both positive real numbers.

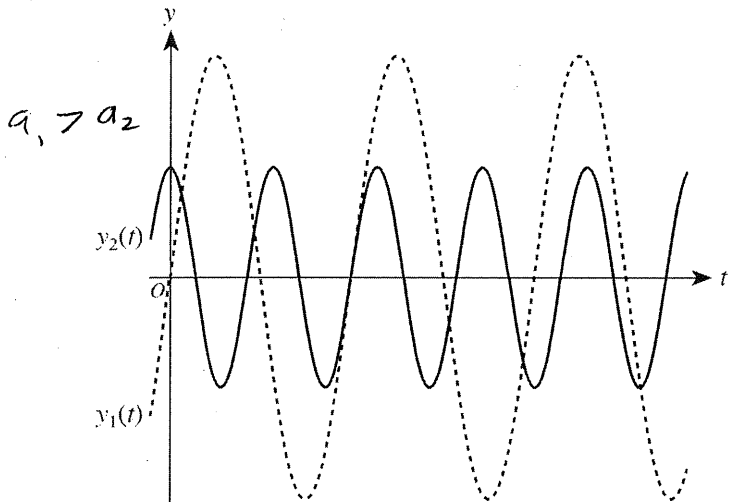

Which of the following statements is true of the constants a_1 and a_2 ?

- A. $0 < a_1 < a_2$
- B. $0 < a_2 < a_1$**
- C. $a_1 < 0 < a_2$
- D. $a_1 < a_2 < 0$
- E. $a_2 < a_1 < 0$

56. For x such that $0 < x < \frac{\pi}{2}$, the expression

$\frac{\sqrt{1-\cos^2 x}}{\sin x} + \frac{\sqrt{1-\sin^2 x}}{\cos x}$ is equivalent to:

- F. 0
- G. 1
- H. 2**
- J. $-\tan x$
- K. $\sin 2x$

$\sqrt{\sin^2 x} + \sqrt{\cos^2 x}$

$1 + 1 = 2$

57. Consider the functions $f(x) = \sqrt{x}$ and $g(x) = 7x + b$. In the standard (x,y) coordinate plane, $y = f(g(x))$ passes through $(4,6)$. What is the value of b ?

- A. 8**
- B. -8
- C. -25
- D. -26
- E. $4 - 7\sqrt{6}$

$y = \sqrt{x}$ $y_2 = 7x + b$

$f(g(x)) = \sqrt{7x + b}$

$(6)^2 = (\sqrt{7(4) + b})^2$

$36 = 28 + b$

$8 = b$

58. The triangle, $\triangle XYZ$, that is shown below has side lengths of x , y , and z inches and is not a right triangle. Let X' be the image of X when the triangle is reflected across \overline{YZ} . Which of the following is an expression for the perimeter, in inches, of quadrilateral $X'YXZ$?

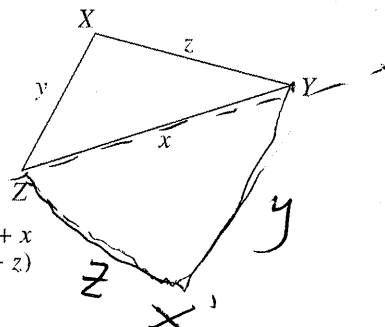

- F. $2(y + z) + x$
- G. $2(x + y + z)$
- H. $2(x + y)$
- J. $2(x + z)$
- K. $2(y + z)$**

59. A function f is an odd function if and only if $f(-x) = -f(x)$ for every value of x in the domain of f . One of the functions graphed in the standard (x,y) coordinate plane below is an odd function. Which one?

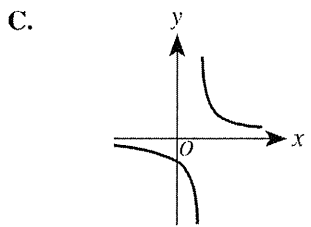
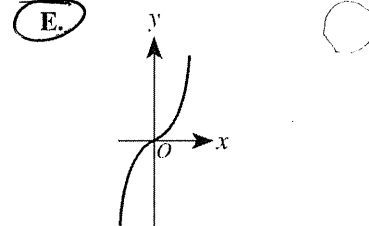
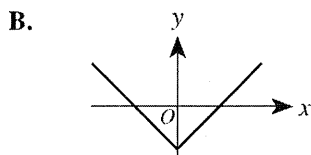
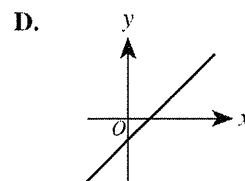
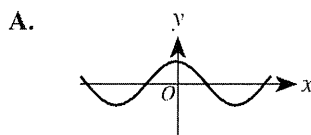

$2^3 = 8$
 $\log_2 8 = y$

60. What is the real value of x in the equation $\log_2 24 - \log_2 3 = \log_5 x$?

- F. 3
- G. 21
- H. 72
- D. 125**
- K. 243

$\log_2 \left(\frac{24}{3}\right) = \log_2 8$

$\log_5 x = y$

$5^y = 125$

$\log_2 8 = \log_5 x$

$2^3 = 8 \rightarrow 5^3 = x$

END OF TEST 2

STOP! DO NOT TURN THE PAGE UNTIL TOLD TO DO SO.

DO NOT RETURN TO THE PREVIOUS TEST.

$\frac{\log 8}{\log 2} = \frac{\log x}{\log 5}$

Test 2: Mathematics—Scoring Key

	Key	Subscore Area*				Key	Subscore Area*		
		EA	AG	GT			EA	AG	GT
1.	A	_____			31.	E		_____	
2.	K	_____			32.	F		_____	_____
3.	B	_____			33.	C	_____		
4.	G		_____		34.	J	_____		
5.	E	_____			35.	B			_____
6.	H	_____			36.	K		_____	
7.	E	_____			37.	C		_____	
8.	G	_____			38.	J		_____	
9.	B			_____	39.	C			_____
10.	J		_____		40.	H		_____	
11.	E	_____			41.	A	_____		
12.	J		_____		42.	F		_____	
13.	B	_____			43.	D		_____	
14.	G			_____	44.	F			_____
15.	C			_____	45.	C			_____
16.	G			_____	46.	K			_____
17.	A	_____			47.	C	_____		
18.	H			_____	48.	J	_____		
19.	C	_____			49.	D		_____	
20.	K	_____			50.	J		_____	
21.	B	_____			51.	E	_____		
22.	K		_____		52.	J	_____		
23.	A	_____			53.	A		_____	
24.	F	_____			54.	K			_____
25.	D			_____	55.	B			_____
26.	J		_____		56.	H			_____
27.	A	_____			57.	A	_____		
28.	H	_____			58.	K			_____
29.	C			_____	59.	E		_____	
30.	G			_____	60.	J		_____	

Number Correct (Raw Score) for:	
Pre-Alg./Elem. Alg. (EA) Subscore Area	_____ (24)
Inter. Alg./Coord. Geo. (AG) Subscore Area	_____ (18)
Plane Geo./Trig. (GT) Subscore Area	_____ (18)
Total Number Correct for Math Test (EA + AG + GT)	_____ (60)

* EA = Pre-Algebra/Elementary Algebra
 AG = Intermediate Algebra/Coordinate Geometry
 GT = Plane Geometry/Trigonometry

0661C

